

PETROL

Instruments



PETROL[®]

PD FLOWMETERS
Manufactured in Italy since 1970

PRODUCTION LINE

"PETROL INSTRUMENTS" has developed the Roots principle for the volumetric measurement of liquids flowing through a pipe. Since its commercial debut this PD flowmeter has contributed to the automation and modernization of the industrial processes for its reliability and its exceptional operating characteristics coupled with a very high manufacturing technique.

"PETROL" PD flowmeters are today available for the measurement of all the liquids industrially used in a range of models so wide, either in the standard version either in the jacketed version, to meet, even contemporarily, operating specifications as severe as:

- max operating pressures till over 150 BAR;
- max operating temperatures till over 250 °C.
- flow rate ranges from few hundreds of litres/hour to 2000 m³/h, with equipment sizes from 1" to 16".

Several manufacturing and operating features, hereinafter evidenced, have permitted to "PETROL" PD flowmeters to be considered a practically unreplaceable equipment in many fields of application and have also allowed its use in many different industrial sectors.

a) Double case construction

The measuring unit is removable, as a single subassy, from the outer housing flanged to the pipe and may be maintained as well as functionally rechecked independently from the outer housing.

b) "Floating" type rotors

Rotors never touch each other but are synchronized by timing gears mounted outside the measuring chamber.

Rotors are not therefore subject to wear and PD flowmeter does not need re-calibration with time due to wearing.

c) Constant profile cutters for rotors machining

This type of rotors machining permits to realize, between the PD flowmeter "base volume" components, "tolerances" or "clearances" suitable for the accurate measurement either of extremely viscous liquids either of mediums at high operating temperatures.

d) Construction materials

Any type of construction material may be used such as aluminum, cast iron, carbon steel, stainless steel in the various available grades and plastic materials as "moplen" either for the measuring unit either for the outer housing flanged to the pipe, in accordance to the specific needs of the clients.

e) Magnetic transmission

With this type of movement transmission, used in the majority of the meters produced, the sealing between the wetted parts and the dry parts of the PD flowmeter is of static type, and this fully guarantees against any leakage of the flowing liquid.

f) Excellent accuracy and repeatability

Accuracy : $\pm 0,15\%$ of reading for custody transfer applications;
 $\pm 0,5\%$ of reading for industrial applications.
Repeatability : $\pm 0,02\%$.

g) Long life and very reduced maintenance

Rotors never touch each other and therefore are not subject to wear. More over double case construction allows to maintain the measuring unit without removing the entire PD flowmeter from the line.

h) Wide range of ancillary equipment

Electronic or pneumatic pulse transmitters and frequency to current converters are available for remote totalization, recording and presetting of metered volumes. Local or remote preset counters, both with one or two stages closure cycles, together with automatic temperature compensators, mechanic or electronic type, complete the range of PD flowmeter ancillary equipment. All the range of protective devices such as strainers, deaerators, max flow limiting and one or two stages closures valves are also available.

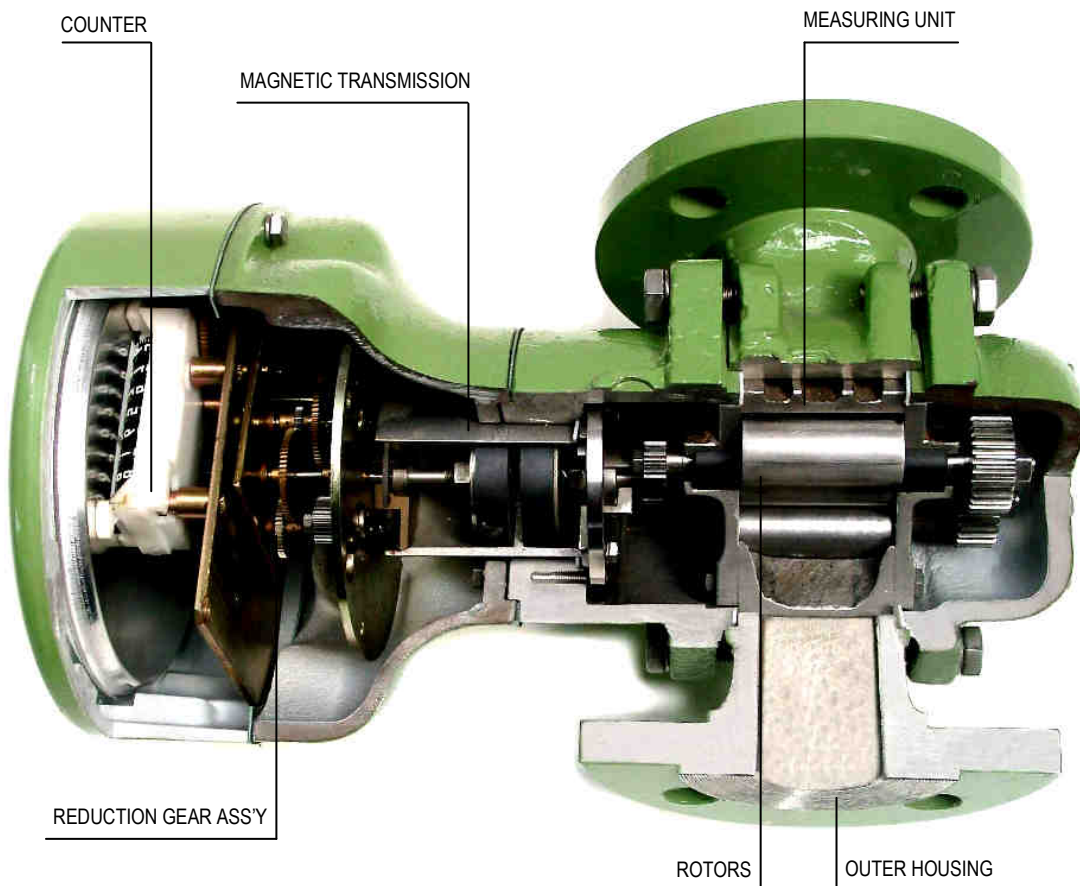

MEASURING UNIT IS REMOVABLE FROM OUTER HOUSING AS A SINGLE SUB-ASS'Y

"PETROL" PD FLOWMETERS



Approved by Industry and Commerce Ministry, Weight and Measure Dept.
with D.M. 28/7/1970 n. 347828 for Italy and D.M.18/10/2006 n. 06.03.01.011 for EEC Countries

"PETROL" PD flowmeters are typical volumetric instruments which directly measure the quantity of flowing liquid by means of a couple of rotors. **These instruments, totally manufactured in Italy since more than 30 years**, allow an accurate measurement either of the flow rate

either of the volumes flown (integrated flow rate) of practically all the liquids industrially utilized. They may be used for custody transfer purposes, operating controls and for the many other needs of the petroleum, chemical, pharmaceutical industry, etc.

OPERATING SCHEME

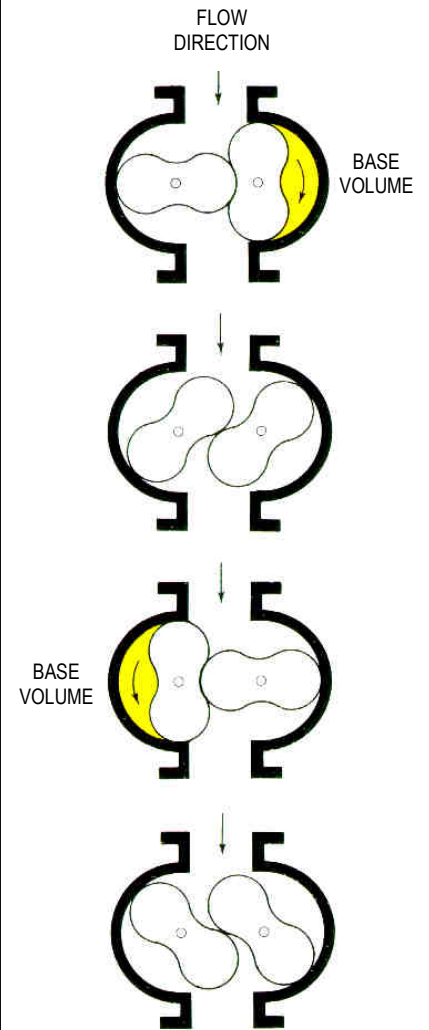

OPERATING PRINCIPLE

The two rotors, engineered and manufactured in such a way they never touch each other nor the measuring unit components, are alternatively driven by the timing gears coupled on rotor shafts just outside the measuring chamber.

As shown in the operating scheme, the liquid flowing inside the PD flowmeter pushes the rotor on the right, which is in condition of unbalanced pressure, to rotate clockwise; contemporarily the rotor on the left, being driven by the timing gears, is forced to rotate counterclockwise.

After a 90° rotation, the rotors are in a reciprocal position when compared to the initial one and therefore it is the rotor on the left which, pushed from the liquid, rotates counterclockwise driving, through the timing gears, the rotor on the right. During these operating cycles, the volume generated between the rotors and the components of the measuring chamber determine the "base volume" of the instrument. A complete rotors' rotation generates four "base volumes". By transmitting the number of rotors' rotations to the register the volume flown through the PD flowmeters is displayed.

MAIN FEATURES

1. Excellent accuracy.
2. Low pressure drop.
3. Double case construction.
4. Floating type rotors.
5. Long life and very reduced maintenance.
6. Compact design (no upstream or downstream pipe lengths are necessary).
7. Wide range of construction materials (cast iron, carbon steel, stainless steel up to AISI 316L, monel, plastic materials, etc).
8. Magnetic transmission (alternatively mechanic).
9. Replacing gear calibrator, (alternatively clutch type).
10. Carbon bearings to support rotors shafts (alternatively ball bearings).
11. Wide range of reading/remote transmission accessories.
12. Wide range of protecting devices.
13. Conformity with International Standards.

MEASURING UNIT

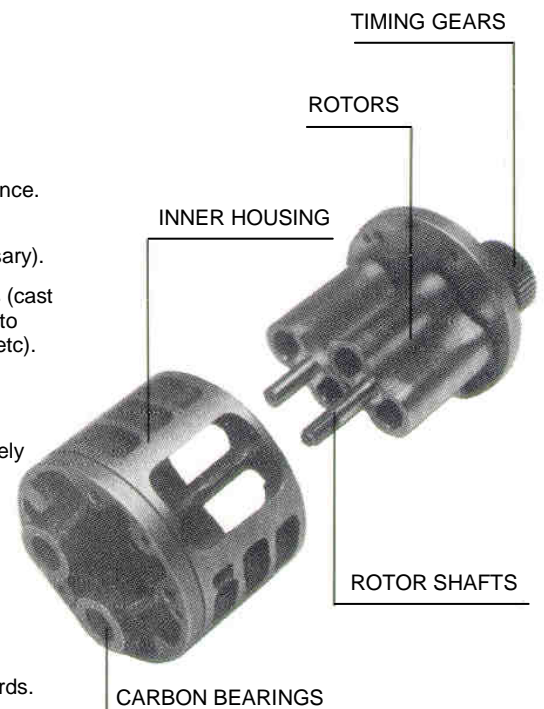

HOW TO SELECT

To write down the identification model of a PD flowmeter, it is recommended to follow the underdetailed codification.

PD FLOWMETER TYPE

F standard
FJ jacketed

MAX OPERATING PRESSURE

(See table)

PD FLOWMETER MODEL

From the table "flow rate ranges" select the PD flowmeter model more suitable for the specific needs with reference to the type of liquid to be metered and to its operating viscosity.

COUNTER

From the table "counters" select the model more suitable for the specific needs. For eventual accessories add the following letters:

P for electric pulse transmitter;
N for pneumatic pulse transmitter;
T for automatic temperature compensator.

For operating temperatures above 100 °C the PD flowmeter is equipped with mod. AK-5 air-fin cooler. Adaptors to incline the counter by 45° or 90° are also available.

CONSTRUCTION MATERIALS

From the relevant "tables" select the construction material more suitable for the specific needs either for what concerns the outer housing either for what concern the measuring unit.

PD flowmeters in plastic materials (Moplen and PVC) are available on request.

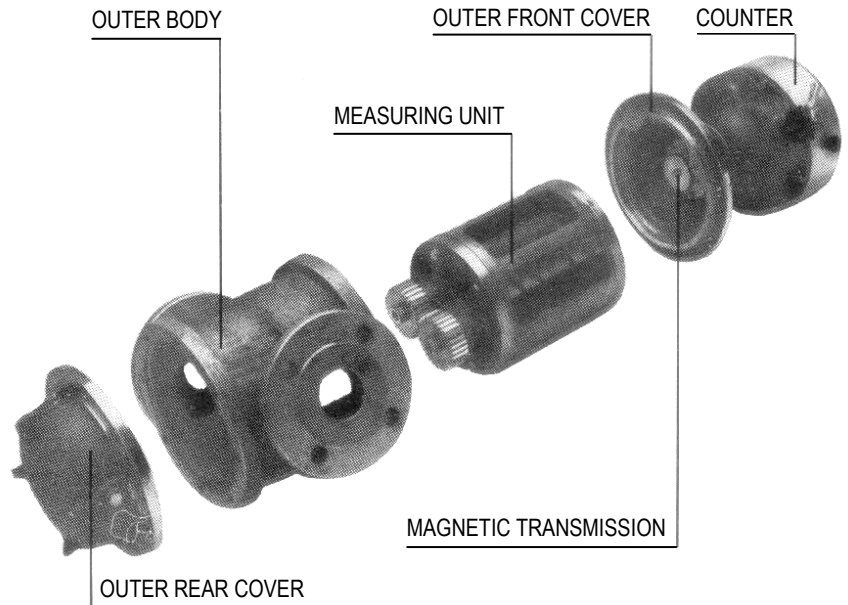

MAX PRESSURE

CODE	MPa
A	1
L	2
M	6,2
H	11
X	>11

F A 24 - 12 - F 8

IDENTIFICATION CODE

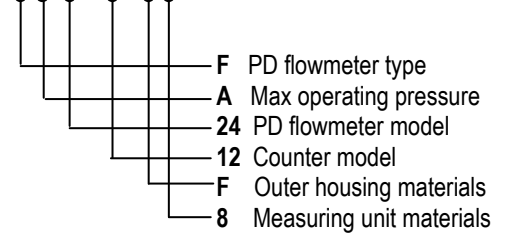

COUNTERS

MOD. 12	Mechanical counter with 10 figures non reset type totalizer (8 on digits plus 2 on dial).
MOD. 22	Mechanical counter with 8 figures reset type totalizer (6 on digits plus 2 on dial) and with 8 digits non reset type totalizer.
MOD. VR	Counter with 5 large figures reset type totalizer, 8 digits non reset type totalizer, 5 figures settable through single push buttons preset counter (optional) and 5 digits zero-start or 7 digits accumulative type ticket printer (optional).
MOD. E	Electronic counter for fiscal applications with optional preset and temperature compensation functions.
MOD. F	Intrinsically safe digital totalizer and flow indicator with optional pulse output and/or 4÷20 mA output.
MOD. K	Explosion proof digital totalizer and flow indicator with optional pulse output and/or 4÷20 mA output.
MOD. H	Hart transmitter with digital indicator (EEx-d or EEx-ia).

COUNTER MODELS



MOD. 12



MOD. 22



MOD. VR



MOD. F



MOD. K



MOD. H

OUTER HOUSING MATERIALS

CODE	BODY/COVERS	GASKETS
A	CAST IRON	TEFLON
B	BRONZE	TEFLON
C	CARBON STEEL	TEFLON
D	DUCTILE IRON	TEFLON
E	AISI 304	TEFLON
F	AISI 316	TEFLON
G	AISI 316 L	TEFLON
H	LOW TEMPERAT. CARBON STEEL	TEFLON

Transmission of movement is normally of magnetic type for all the codes.

MEASURING UNIT MATERIALS

CODE	HOUSING	ROTORS
1	BRONZE	BRONZE
2	BRONZE	ALUMINUM
3	CAST IRON	ALUMINUM
5	CAST IRON	CAST IRON
7	AISI 304	AISI 304
8	AISI 316	AISI 316
9	AISI 316 L	AISI 316 L

Bearings are normally made of carbon while rotor shafts and timing gears are in stainless steel.

FLOW RATE RANGES (m³/h)

			PETROLEUM PRODUCTS				WATER	CHEMICAL PRODUCTS			
MOD.	Ø LINE	mPa.s SERVICE	> 0,5	2	10	150	T < 80 °C	Soda 30%	50	500	2000
51	25	Continuous	0,6 ÷ 2,5	0,5 ÷ 2,5	0,2 ÷ 3,5	0,05 ÷ 3,5	0,5 ÷ 2,3	0,2 ÷ 2,5	0,1 ÷ 3,5	0,02 ÷ 2,5	0,008 ÷ 2
	40	Intermittent	0,6 ÷ 3,5	0,5 ÷ 3,5	0,2 ÷ 4	0,05 ÷ 4	0,5 ÷ 2,8	0,2 ÷ 3,5	0,1 ÷ 4	0,02 ÷ 3,5	0,008 ÷ 2,5
11	25	Continuous	1 ÷ 4,5	0,8 ÷ 4,5	0,3 ÷ 6	0,07 ÷ 6	0,9 ÷ 4	0,3 ÷ 4,5	0,15 ÷ 6	0,04 ÷ 4,5	0,015 ÷ 3,5
	40	Intermittent	1 ÷ 6	0,8 ÷ 6	0,3 ÷ 7	0,07 ÷ 7	0,9 ÷ 5	0,3 ÷ 6	0,15 ÷ 7	0,04 ÷ 6	0,015 ÷ 4,5
12	40	Continuous	2 ÷ 9	1,5 ÷ 9	0,6 ÷ 13	0,15 ÷ 13	1,8 ÷ 8,5	0,6 ÷ 9	0,3 ÷ 13	0,08 ÷ 9	0,03 ÷ 7,5
	50	Intermittent	2 ÷ 13	1,5 ÷ 13	0,6 ÷ 15	0,15 ÷ 15	1,8 ÷ 10,5	0,6 ÷ 13	0,3 ÷ 15	0,08 ÷ 13	0,03 ÷ 9
22	50	Continuous	2,5 ÷ 14	2 ÷ 14	1 ÷ 20	0,25 ÷ 20	2,3 ÷ 13	1 ÷ 14	0,5 ÷ 20	0,12 ÷ 14	0,05 ÷ 12
	65	Intermittent	2,5 ÷ 20	2 ÷ 20	1 ÷ 24	0,25 ÷ 24	2,3 ÷ 16,5	1 ÷ 20	0,5 ÷ 24	0,12 ÷ 20	0,05 ÷ 14
53	50	Continuous	5 ÷ 25	4 ÷ 25	2 ÷ 35	0,5 ÷ 35	4,5 ÷ 22,5	2 ÷ 25	1 ÷ 35	0,25 ÷ 25	0,1 ÷ 20
	80	Intermittent	5 ÷ 35	4 ÷ 35	2 ÷ 40	0,5 ÷ 40	4,5 ÷ 28	2 ÷ 35	1 ÷ 40	0,25 ÷ 35	0,1 ÷ 25
13	50	Continuous	6,5 ÷ 35	5 ÷ 35	2,5 ÷ 50	0,6 ÷ 50	6 ÷ 34	2,5 ÷ 35	1,2 ÷ 50	0,3 ÷ 35	0,12 ÷ 30
	80	Intermittent	6,5 ÷ 50	5 ÷ 50	2,5 ÷ 60	0,6 ÷ 60	6 ÷ 42	2,5 ÷ 50	1,2 ÷ 60	0,3 ÷ 50	0,12 ÷ 35
14	80	Continuous	13 ÷ 65	10 ÷ 65	4,5 ÷ 90	1,2 ÷ 90	12 ÷ 60	4,5 ÷ 65	2,3 ÷ 90	0,6 ÷ 65	0,25 ÷ 55
	100	Intermittent	13 ÷ 90	10 ÷ 90	4,5 ÷ 110	1,2 ÷ 110	12 ÷ 75	4,5 ÷ 90	2,3 ÷ 110	0,6 ÷ 90	0,25 ÷ 65
24	80	Continuous	18 ÷ 90	14 ÷ 90	6 ÷ 125	1,5 ÷ 125	16 ÷ 80	6 ÷ 90	3 ÷ 125	0,75 ÷ 90	0,3 ÷ 75
	100	Intermittent	18 ÷ 125	14 ÷ 125	6 ÷ 150	1,5 ÷ 150	16 ÷ 100	6 ÷ 125	3 ÷ 150	0,75 ÷ 125	0,3 ÷ 90
16	100	Continuous	24 ÷ 110	18 ÷ 110	8 ÷ 150	2 ÷ 150	20 ÷ 100	8 ÷ 110	4 ÷ 150	1 ÷ 110	0,4 ÷ 90
	150	Intermittent	24 ÷ 150	18 ÷ 150	8 ÷ 180	2 ÷ 180	20 ÷ 125	8 ÷ 150	4 ÷ 180	1 ÷ 150	0,4 ÷ 110
18	150	Continuous	35 ÷ 150	25 ÷ 150	12 ÷ 210	3 ÷ 210	30 ÷ 140	12 ÷ 150	6 ÷ 210	1,5 ÷ 150	0,6 ÷ 125
	200	Intermittent	35 ÷ 210	25 ÷ 210	12 ÷ 250	3 ÷ 250	30 ÷ 175	12 ÷ 210	6 ÷ 250	1,5 ÷ 210	0,6 ÷ 150
28	150	Continuous	40 ÷ 190	30 ÷ 190	15 ÷ 270	4 ÷ 270	35 ÷ 180	15 ÷ 190	7,5 ÷ 270	2 ÷ 190	0,8 ÷ 160
	200	Intermittent	40 ÷ 270	30 ÷ 270	15 ÷ 320	4 ÷ 320	35 ÷ 225	15 ÷ 270	7,5 ÷ 320	2 ÷ 270	0,8 ÷ 190
110	200	Continuous	60 ÷ 270	40 ÷ 270	20 ÷ 380	4,5 ÷ 380					
	250	Intermittent	60 ÷ 380	40 ÷ 380	20 ÷ 450	4,5 ÷ 450					
112	250	Continuous	80 ÷ 350	60 ÷ 350	25 ÷ 500	6,5 ÷ 500					
	300	Intermittent	80 ÷ 500	60 ÷ 500	25 ÷ 600	6,5 ÷ 600					
212	250	Continuous	130 ÷ 600	100 ÷ 600	45 ÷ 850	10 ÷ 850					
	300	Intermittent	130 ÷ 850	100 ÷ 850	45 ÷ 1000	10 ÷ 1000					
612	300	Continuous	160 ÷ 850	125 ÷ 850	60 ÷ 1200	14 ÷ 1200					
	350	Intermittent	160 ÷ 1200	125 ÷ 1200	60 ÷ 1400	14 ÷ 1400					
114	350	Continuous	200 ÷ 1100	150 ÷ 1100	75 ÷ 1500	18 ÷ 1500					
	400	Intermittent	200 ÷ 1500	150 ÷ 1500	75 ÷ 1800	18 ÷ 1800					

Ø LINE IS THE DIMENSION OF THE FLANGE COUPLED TO THE PIPE

Viscosity °E

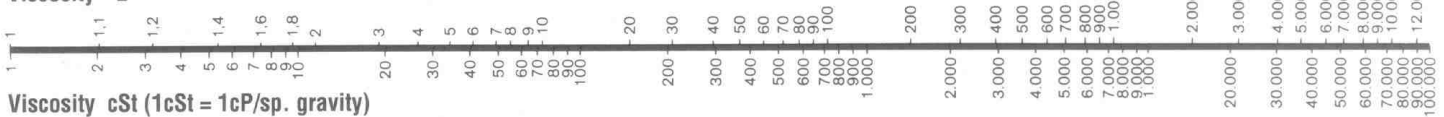

Viscosity cSt (1cSt = 1cP/sp. gravity)

CHARACTERISTIC CURVES

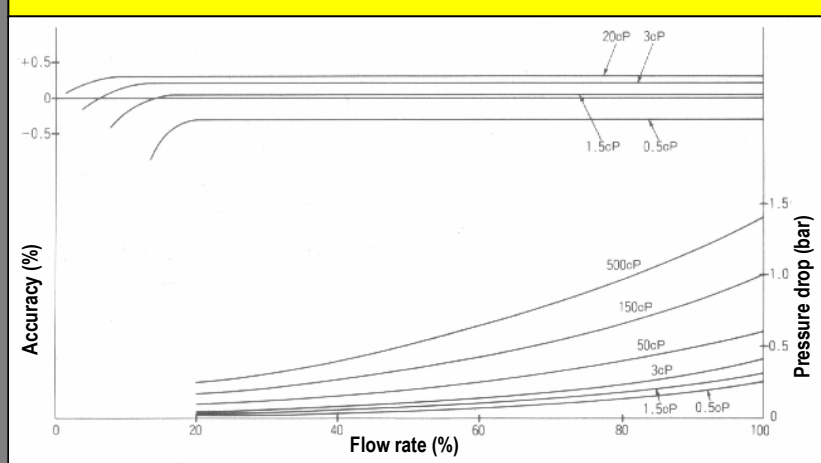

NOTES ON FLOW RATE RANGES

The "flow rate ranges" table has been prepared very conservatively to allow anybody to ask for a quotation or to select a "PETROL" PD flowmeter, provided liquid temperature is below 80 °C.

It is possible to use "PETROL" PD flowmeters outside specified flow rate ranges and viscosities but in such cases it is necessary to consult the factory. Continuous service means 8/24 hours of operation per day.

The max allowed flow rate is about 20% higher than that shown on the table.

For liquid with a viscosity above 10 cP is normally specified a 1:10 flow rate range within the limits mentioned in the table.

PD flowmeters accuracy is in accordance with the official approvals issued by Italian Industry and Commerce Ministry, Weight and Measure Dept. for their installation in Italy and in the European Common Market Countries.

PD FLOWMETERS OUTLINE DIMENSIONS

VERSION WITH HORIZONTAL ROTOR SHAFTS

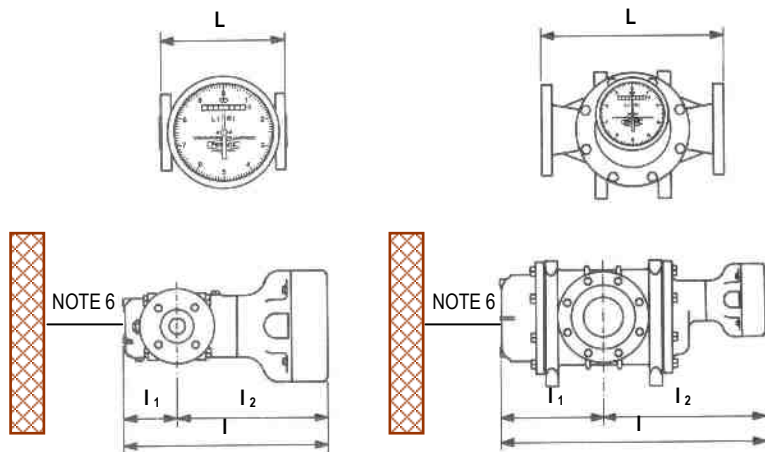

MOD.	L	I	I1	I2
51	200	311	78	233
11	200	329	86	243
12	250	375	110	265
22	250	425	135	290
53	320	432	148	284
13	320	492	178	314

MOD.	L	I	I1	I2
14	380	564	209	355
24	450	655	255	400
16	610	703	243	460
18	610	793	288	505
28	640	889	335	554
110	640	889	335	554
112	650	1138	511	627

VERSION WITH VERTICAL ROTOR SHAFTS

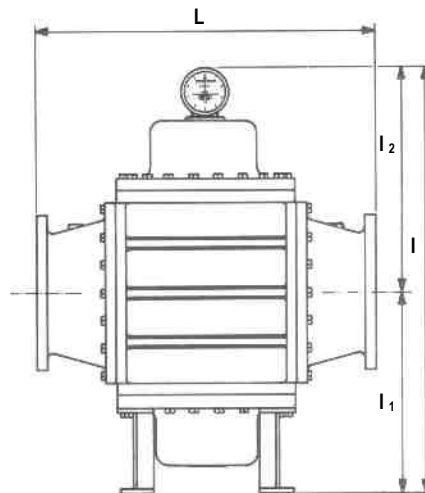

MOD.	L	I	I1	I2
212	1200	1423	678	745
612	1305	1623	778	845
114	1400	1723	828	895

DIMENSIONS VALID FOR PD FLOWMETERS FLANGED ANSI 150 RF AND UNI PN 10/16

TYPICAL INSTALLATIONS

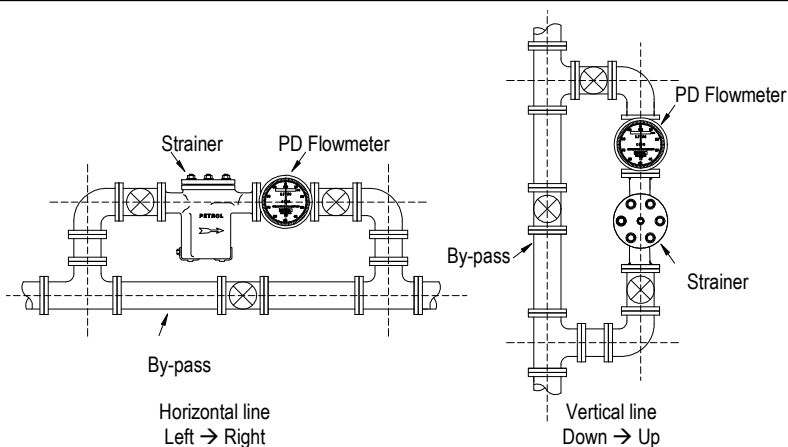

PRECAUTIONS

1. The majority of PD flowmeters troubles is caused by solid particles which, entering the measuring mechanism, block the rotors. Before the start-up be sure that the inlet line to PD flowmeter has been properly cleaned.
2. During the installation avoid to apply any stress to PD flowmeter and be sure that the flow direction agrees with the arrow stamped on equipment body.
3. Couple the protection strainer directly on the PD flowmeter inlet flange. More-over equip the line with a by-pass to be used also for cleaning.
4. Use the PD flowmeter within the flow rate range, max pressure and max temperature printed in the nameplate.
5. PD flowmeters over 3" size shall be duly anchored on a strong foundation.
6. The measuring unit of horizontal type PD flowmeters is removed from the rear; **leave enough space for its removal.**
7. On PD flowmeters with horizontal rotor shafts the flow direction may be: left-right, right-left, down-up, up down. However the rotor shafts must be compulsory installed in horizontal position with register in vertical position (as shown in the picture).

INSTALLATION ON HORIZONTAL PIPES

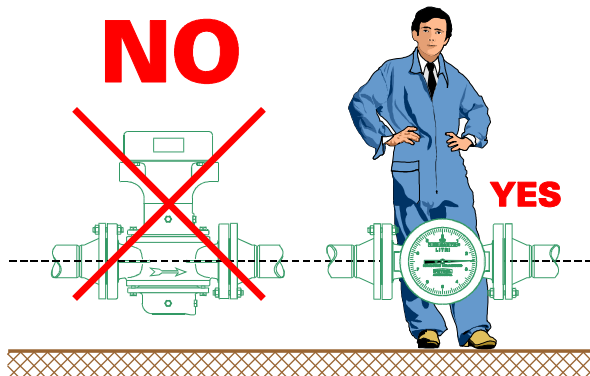

MAIN APPLICATION FIELDS

PETROLEUM INDUSTRY

Asphalt, bitumen, crude-oil, gasoil, gasoline, heavy oils, jp4, light-oil, LPG, lubricants, kerosene, virgin naphta.

CHEMICAL INDUSTRY

Acetic acid, alcohol, diluted and concentrated caustic soda, demi water, HCL, nitric acid, saline solutions, solvents, sulphuric acid, VCM.

CRUDE OIL EXTRACTION

Crude oil, ethylen glycol, gasoil, glycol, sour oil, water.

SHIPS AND STEEL MAKING INDUSTRY

Bunker C, gasoil, light-oil, lubricants, turbine-oil, water, sea water.

PETROCHEMICAL INDUSTRY

Acetaldehyde, acetone, acrilonytrile, benzene, butanol, ethanol, ethylene, LPG, maleic / phtalic anhydride, propylene, styrene, toluene, xylene.

PHARMACEUTICAL INDUSTRY

Acid solutions, caustic soda, demi water, HCl diluted, H₂SO₄ diluted and concentrated, phosphoric acid.

POWER PLANTS INDUSTRY

Bunker C, crude-oil, demi water, diesel oil, diathermic oil, gasoil.

MISCELLANEOUS

Antifreezing solutions, DDB, DDBS, MMA, plasticizers, vegetal oils, varnish.

SPECIALISTS

During the years "PETROL INSTRUMENTS" has accumulated a very strong experience to allow also the production of PD flowmeters suitable for the heaviest operating conditions in the more different industrial fields such as: the measurement of blood, of phtalic and of maleic anhydride, of crude oil on well-heads, of heavy oils at high temperatures and of sea water. Such a technical background and the investments yearly destined to the research in the field of the volumetric measurement of liquids have till now satisfied each particular need of the customers. Herebelow there are some pictures of PD flowmeters for special applications and after are listed the most significant references for crude oil extration industry and for power generation plants.



Ship loading skid



Pneumatic batch system



Truck loading bay

HOMOLOGATIONS

1. Approval n. 347828 dated 28/07/70, issued by Italian Weight and Measure Department, for legal and custody transfer applications in Italy.
2. Approval n. 10596 dated 10/09/2004, issued by Italian Weight and Measure Department, for the legal application in Italy of the "Master Meters Petrol Instruments".
3. Compliance with OIML R117.
4. Approval n. 23679 dated 25/04/2006 issued by the Russian Authority for the legal use in Russia.
5. Approval n. 1115 del 03/08/2006 issued by Pascal, attesting the conformity of our products to the PED directive n. 97/23/EC.
6. EC Declaration of Conformity (ATEX, PED).
7. CEE Approval n. 06.03.01.011 dated 18/10/06, issued by Italian Weight and Measure Department for the legal use in European Common Market (CEE) Countries.
8. MIGAS Approval issued by the Indonesian Authority for the legal use in Indonesia.
9. DPR Approval issued by Department of Petroleum Resources for the legal use in Nigeria.
10. Approval issued by AQSIC (PAC) for the legal use in China.
11. ISO 9001:2000 Certificate issued by Bureau Veritas Italia.
12. ISO 14001:2004 Certificate issued by IQNet.

CRUDE OIL EXTRACTION

OFF-SHORE ITALY:

Agostino, Amelia, Angela / Angelina, Annalisa, Aquila, Barbara, Cervia, Daria, Emilio, Emma, Fratello, Garibaldi, Giovanna, Hera Lacinia, Luna, Nilde, Pennina, Perla, Prezioso, Regina, Squalo, Vega.

OFF-SHORE ABROAD:

Brasil (P37 Marlim Field), *China* (HZ21/26 South China Sea, Liao Dong Bay), *Croazia* (Ivana), *Congo* (Loango, ZAF1), *England North Sea* (Texaco Erskine, Elgin Franklin, Almeda), *Libya* (Bouri), *Nigeria* (Agbara, Bonny Island), *Vietnam* (CPP-2 White Tiger)

ON SHORE ITALY:

Cavone, Gaggiano, Gela, Monte Alpi, Pisticci, Torrente Baganza, Torrente Tona, Trecate, Val D'Agri, Villa Fortuna.

ON SHORE ABROAD:

Austria (Vienna), *Egypt* (Abu-Rudeis, Ras El Barr, Ras Garra), *England* (BP Andrew) *Iran* (On-shore Oil), *Lybia* (North Rimal Field), *Nigeria* (Ebocha, Ogbainbiri).

POWER PLANTS

POWER PLANTS IN ITALY:

Montemartini, Brescia, Ponti sul Mincio, Bastardo, Brindisi Nord, Brindisi Sud, Borgo Trento, Fiume Santo, Priolo, La Spezia, Melilli, Monfalcone, Montalto di Castro, Napoli, Levante, Ostiglia, Pietrafitta, Piombino, Porto Tolle, Rosignano Solvay, S. Barbara, San Filippo del Mela, S. Gilla, Sermide, Sulcis, Tavazzano, Termini Imerese, Torrevaldaliga Nord, Torrevaldaliga Sud, Trino Vercellese, Vado Ligure.

POWER PLANTS ABROAD:

Algeria, Argentina, Cambogia, Chile, China, Egypt, England, Ethiopia, Ghana, Giamaica, Greece, Indonesia, Irak, Ivory Coast, Jordan, Lebanon, Malaysia, Malta, Morocco, Pakistan, Saudi Arabia, Syria, South Africa, Tunisia, Turkey, U.A.E., Uruguay, Venezuela, Yemen.





OUR NEW FACTORY



PETROL Instruments S.r.l.

Via della Tecnica, n. 5 - 04011 Aprilia (LT) - ITALY

Phone +39-06-9201.941 a.r. - Fax +39-06-9201.9446

<http://www.petrol-instruments.com> - e-mail: info@petrol-instruments.com